

### Before crimping

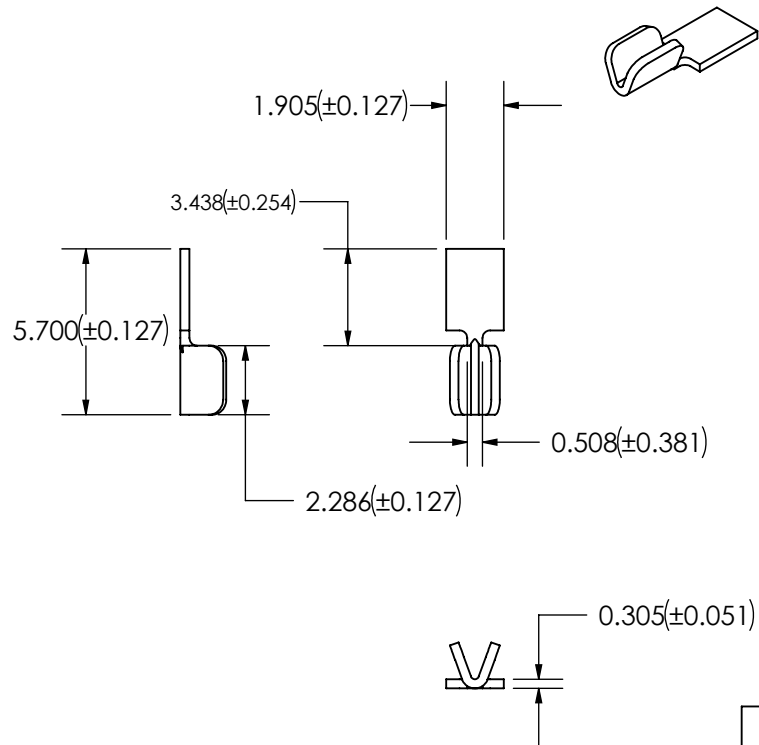

### After crimping\*

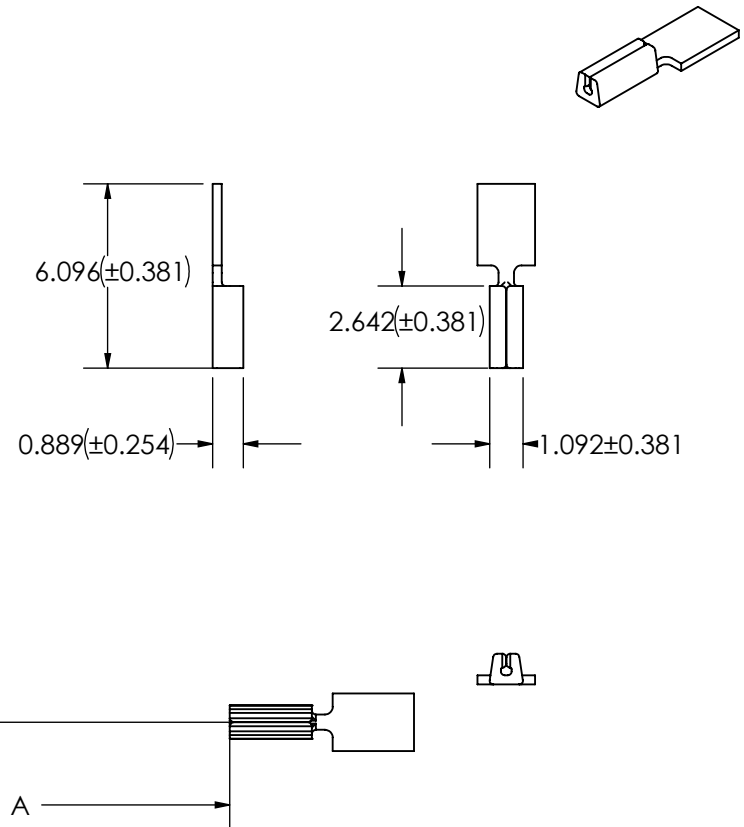

#### REFERENCE ONLY

\*MAY CHANGE SLIGHTLY WITH DIFFERENT WIRE DIAMETERS  
 DOES NOT INCLUDE MINIMAL FLASH/DEFORMATIONS THAT ARE CREATED DURING CRIMPING



SCALE: 4:1

UNITS: mm

#### PROPRIETARY

THE INFORMATION CONTAINED IN THIS DRAWING IS THE SOLE PROPERTY OF DYNALLOY, Inc. ANY REPRODUCTION IN PART OR AS A WHOLE WITHOUT THE WRITTEN PERMISSION OF DYNALLOY, Inc IS PROHIBITED.

TITLE:

Flat Tap #2 Crimp

FORM:

5835

MATERIAL:

Brass

SHEET 1 OF 1