

Before crimping

After crimping*

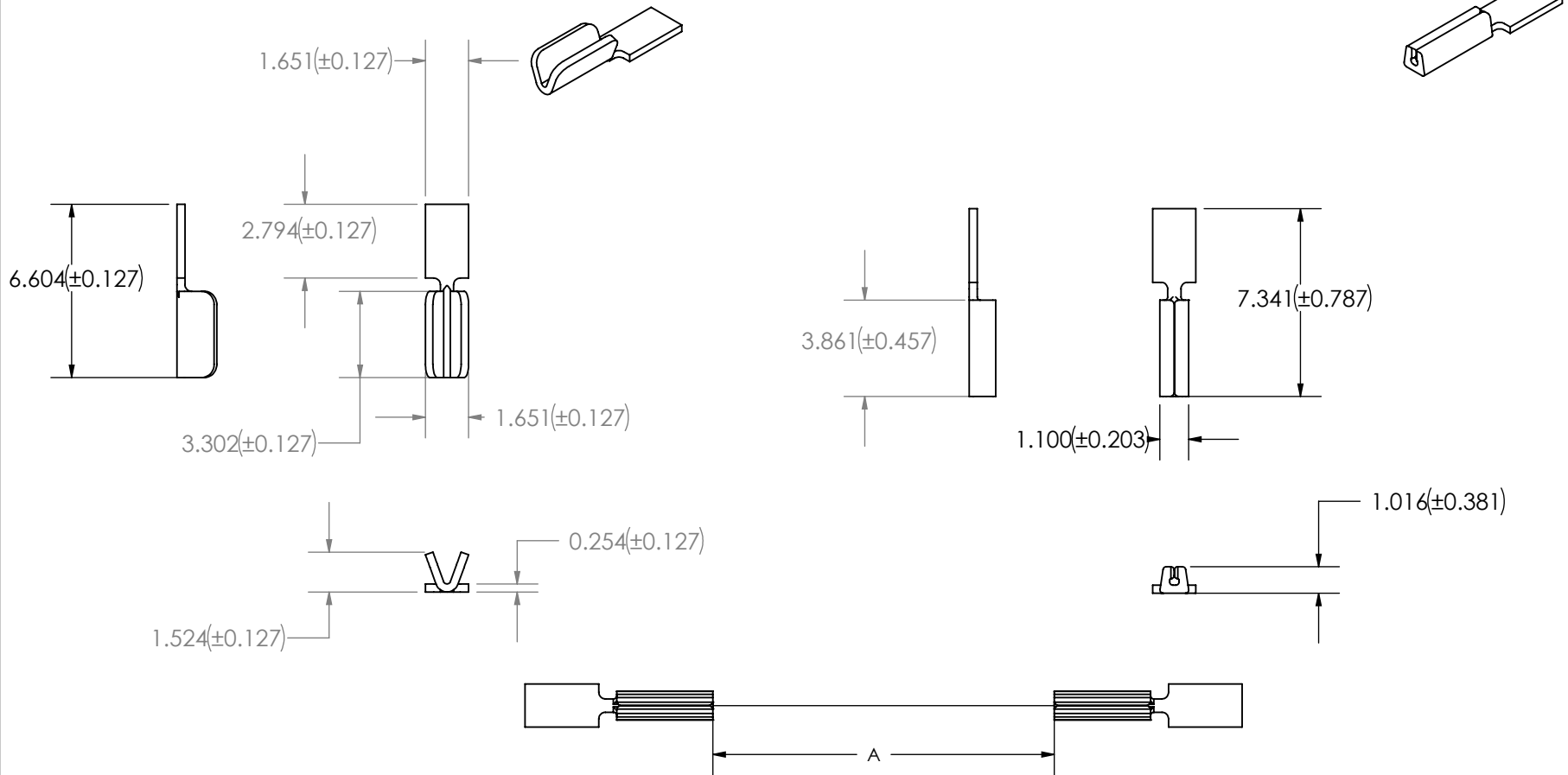

REFERENCE ONLY

*MAY CHANGE SLIGHTLY WITH DIFFERENT WIRE DIAMETERS
 DOES NOT INCLUDE MINIMAL FLASH/DEFORMATIONS THAT ARE CREATED DURING CRIMPING



PROPRIETARY

THE INFORMATION CONTAINED IN THIS DRAWING IS THE SOLE PROPERTY OF DYNALLOY, Inc. ANY REPRODUCTION IN PART OR AS A WHOLE WITHOUT THE WRITTEN PERMISSION OF DYNALLOY, Inc IS PROHIBITED.

SCALE: 4:1

UNITS: mm

TITLE:	Flat Tab #1 Crimp	
FORM:	5670	
MATERIAL:	Brass	SHEET 1 OF 1